



FRONTGRADE

DATASHEET

SCD8663

3A LDO Adjustable Negative Voltage
Regulator

1/23/2024

Version #: 1.0.14

Features

- Manufactured using Analog Devices Space Qualified RH1185 die
- Radiation performance
- Total dose: >100 krad(Si), Dose rate = 50-300 rad(Si)/s
- ELDRS: > 50 krad(Si), Dose rate = 0.01 rad(Si)/s
- Thermal shutdown
- Output voltage adjustable: -2.37 to -25V
- Dropout voltage: 1.05V at 3.0 Amps
- 5-Terminal
- Output current: 3A
- Voltage reference: -2.370V \pm 3%
- Load regulation: 0.8% max
- Line regulation: 0.02% max
- Ripple rejection: >60dB
- Packaging – Hermetic metal
- Hermetic Surface Mount Power Package
- 5 Pads, .545"L x .296"W x .120"Ht
- Weight - 1.2 gm max
- Designed for aerospace and high reliability space applications
- Radiation Hardness Assurance Plan: DLA Certified to MIL-PRF-38534, Appendix G.

Description

The VRG8663 consists of a Negative Adjustable (RH1185) LDO voltage regulator capable of supplying 3.0 Amps over the output voltage range as defined under recommended operating conditions. The VRG8663 offers excellent line and load regulation specifications and ripple rejection. Dropout ($V_{IN} - V_{OUT}$) decreases at lower load currents.

The VRG8663 serves a wide variety of applications including High Efficiency Linear Regulators, Post Regulators for Switching Supplies, Constant Current Regulators, Battery Chargers and Microprocessor Supply.

The VRG8663 has been specifically designed to meet exposure to radiation environments and is configured for a SMD power package. It is guaranteed operational from -55°C to +125°C. Available screened to MIL-STD-883, the VRG8663 is ideal for demanding military and space applications.

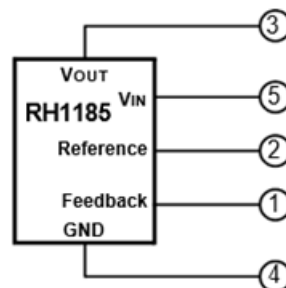

BLOCK DIAGRAM / SCHEMATIC

Absolute Maximum Ratings

PARAMETER	RANGE	UNITS
Input Voltage	-35	VDC
Lead temperature (soldering 10 Sec)	300	°C
Input Output Differential	30	VDC
Feedback & Reference Voltage	-7	VDC
Output Voltage	-30	VDC
ESD	2000 <u>1</u> /	V
Operating Junction Temperature Range	-55 to +150	°C
Storage Temperature Range	-65 to +150	°C

1/ Meets ESD testing per MIL-STD-883, method 3015, Class 1C.

NOTICE: Stresses above those listed under "Absolute Maximums Rating" may cause permanent damage to the device. These are stress rating only; functional operation beyond the "Operation Conditions" is not recommended and extended exposure beyond the "Operation Conditions" may effect device reliability.

Recommended Operating Conditions

PARAMETER	RANGE	UNITS
Output Voltage Range	-2.45 to -25	VDC
Input Output Differential	1 to 28	VDC
Case Operating Temperature Range	-55 to +125	°C

Electrical Performance Characteristics

Unless otherwise specified, $-55^{\circ}\text{C} < T_c < +125^{\circ}\text{C}$.

PARAMETER	SYM	CONDITIONS (P ≤ P _{MAX})	MIN	MAX	UNITS
Reference Voltage (At pin 1) 2/ 7/	VREF	$5\text{mA} \leq \text{IOUT} \leq 3\text{A}$, $\text{VIN} - \text{VOUT} = 1.2\text{V to } 28\text{V}$, $\text{VOUT} = -5\text{V}$	-2.29	-2.45	V
Dropout Voltage 2/ 4/	VDROP	$\text{IOUT} = 0.5\text{A}$, $\text{VOUT} = -5\text{V}$	-	0.425	V
		$\text{IOUT} = 3\text{A}$, $\text{VOUT} = -5\text{V}$	-	1.05	V
Line Regulation 2/ 8/	$\frac{\Delta\text{VOUT}}{\Delta\text{VIN}}$	$1.0\text{V} \leq \text{VIN} - \text{VOUT} \leq 20\text{V}$, $\text{VOUT} = -5\text{V}$, $\text{ILOAD} = 5\text{mA}$	-	0.02	%/V
Load Regulation 2/ 8/	$\frac{\Delta\text{VOUT}}{\Delta\text{IOUT}}$	$5\text{mA} \leq \text{IOUT} \leq 3\text{A}$, $\text{VIN} - \text{VOUT} = 1.5\text{V to } 10\text{V}$, $\text{VOUT} = -5\text{V}$	-	0.8	%
Minimum Input Voltage 2/ 5/	VIN MIN	$\text{IOUT} = 3\text{A}$, $\text{VOUT} = \text{VREF}$	-	-4.5	V
Internal Current Limit (See Figure 4) 2/ 11/	ICL	$1.5\text{V} \leq \text{VIN} - \text{VOUT} \leq 10\text{V}$	3.3	4.55	A
		$\text{VIN} - \text{VOUT} = 15\text{V}$	2.0	4.5	A
		$\text{VIN} - \text{VOUT} = 20\text{V}$	1.0	3.1	A
		$\text{VIN} - \text{VOUT} = 28\text{V}$ 3/	0.2	1.6	A
External Current Limit 2/	ILIM	$\text{RLIM} = 5\text{K}\Omega$ 10/	2.7	3.7	A
		$\text{RLIM} = 15\text{K}\Omega$ 10/	0.9	1.75	A
Quiescent Supply Current 2/ 6/	IQ	$\text{IOUT} = 5\text{mA}$, $\text{VOUT} = \text{VREF}$, $-4\text{V} \leq \text{VIN} \leq -25\text{V}$	-	3.5	mA

Electrical Performance Characteristics

Unless otherwise specified, $-55^{\circ}\text{C} < T_c < +125^{\circ}\text{C}$.

PARAMETER	SYM	CONDITIONS ($P \leq P_{MAX}$)	MIN	MAX	UNITS
Supply Current Change with Load Δ /	IQ Δ	VIN – VOUT = VSAT \geq 9/	-	35	mA/A
		VIN – VOUT \leq 2V	-	21	mA/A
Ripple Rejection	-	IOUT = 1.0A, VIN - VOUT = 3V, f = 120Hz,	60	-	dB
Thermal Regulation (See application info LT1185) Δ /	-	VIN – VOUT = 10V, IOUT = 5mA to 2A, TC = +25°C	-	0.014	%/W
Thermal Resistance (Junction to Case)	Θ_{JC}		-	3	°C/W

Notes:

1. Meets ESD testing per MIL-STD-883, method 3015, Class 2.
2. Specifications derated to reflect Total Dose exposure to 100 krad(Si) @ +25°C.
3. Not tested. Shall be guaranteed by design, characterization, or correlation to other tested parameters.
4. Dropout voltage is tested by reducing input voltage until the output drops 1% below its nominal value. Tests are done at 0.5A and 3A. The power transistor looks basically like a pure resistance in this range so that minimum differential at any intermediate current can be calculated by interpolation; VDROPOUT = 0.25V + (0.25 Ω x IOUT). For load current less than 0.5A, see Figure 3.
5. "Minimum input voltage" is limited by base emitter voltage drive of the power transistor section, not saturation as measured in Note 4. For output voltages below 4V, "minimum input voltage" specification may limit dropout voltage before transistor saturation limitation.
6. Supply current is measured on the ground pin, and does not include load current, RLIM, or output divider current.
7. The 25W power level is guaranteed for an input-output voltage of 8.3V to 17V. At lower voltages the 3Amp limit applies, and at higher voltages the internal power limiting may restrict regulator power below 25W.
8. Line and load regulation are measured on a pulse basis with a pulse width of 2ms, to minimize heating. DC regulation will be affected by thermal regulation and temperature coefficient of the reference.
9. VSAT is the maximum specified dropout voltage: 0.25V + (0.25 x IOUT).
10. Current limit is programmed with a resistor from REF pin to GND. RLIM = 15k Ω /ILIM.
11. Pulsed @ <10% duty cycle @ 25°C.

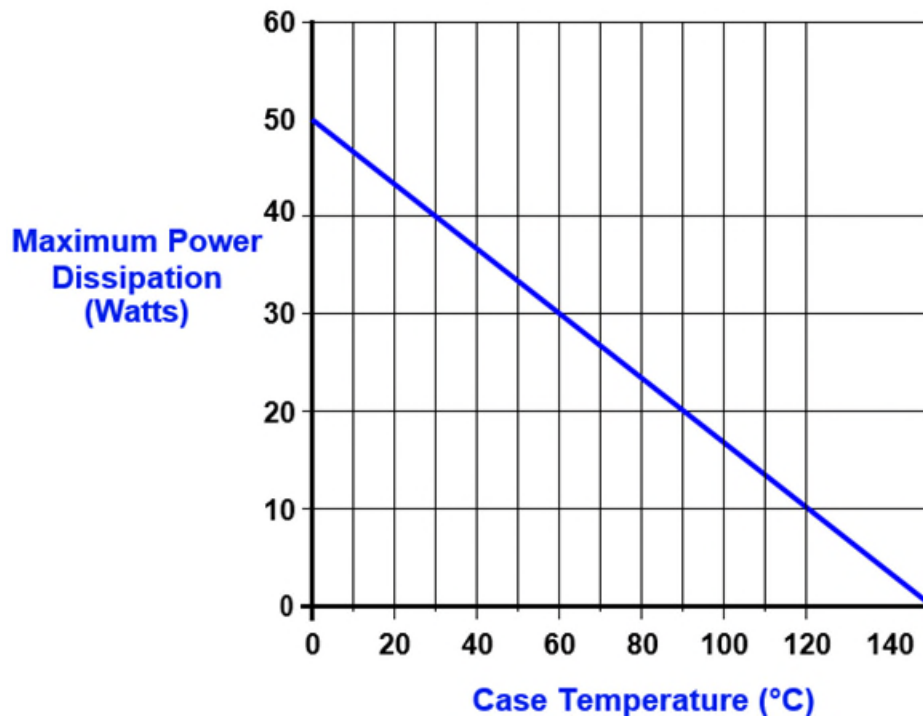

MAXIMUM POWER vs CASE TEMPERATURE

The maximum Power dissipation is limited by the thermal shutdown function of the regulator chip in the VRG8663. The graph above represents the achievable power before the chip shuts down. The line in the graph represents the maximum power dissipation of the VRG8663. This graph is based on the maximum junction temperature of 150°C and a thermal resistance (θ_{JC}) of 3°C/W.

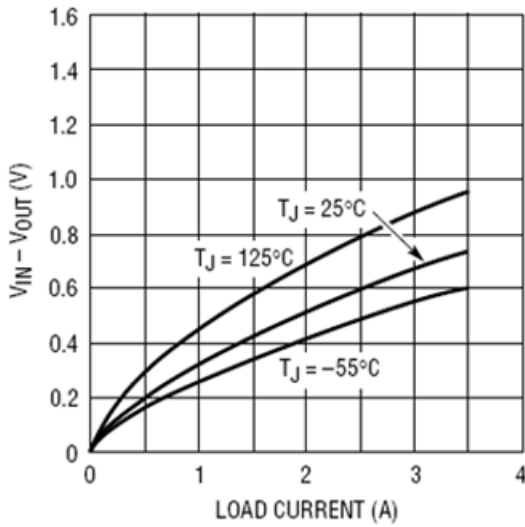

**RH1185 DROPOUT VOLTAGE
TYPICAL CURVE**

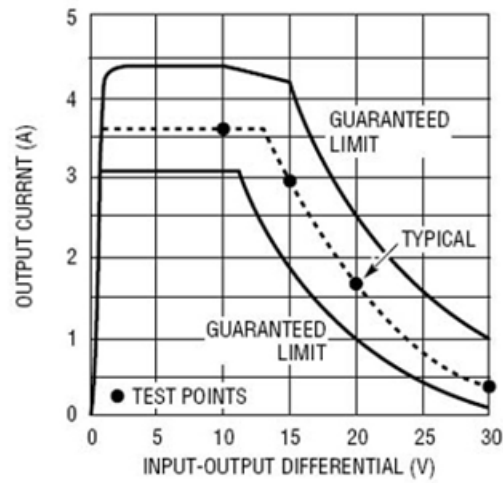

RH1185 INTERNAL CURRENT LIMIT

The RH1185 output voltage is set by two external resistors. Internal reference voltage is trimmed to 2.37V so that a standard 1% 2.37k resistor (R1) can be used to set divider current at 1mA. R2 is then selected from:

$$R2 = \frac{(VOUT - 2.37) R1}{VREF}$$

for R1 = 2.37k and VREF = 2.37V, this reduces to:

$$R2 = \frac{VOUT - 2.37}{10 - 3}$$

suggested values of 1% resistors are shown.

VOUT	R2 WHEN R1 = 2.37k
2.5V	130 ^Ω
3.3V	930 ^Ω
5V	2.67k
12V	9.76k
15V	12.7k

SETTING OUTPUT VOLTAGE

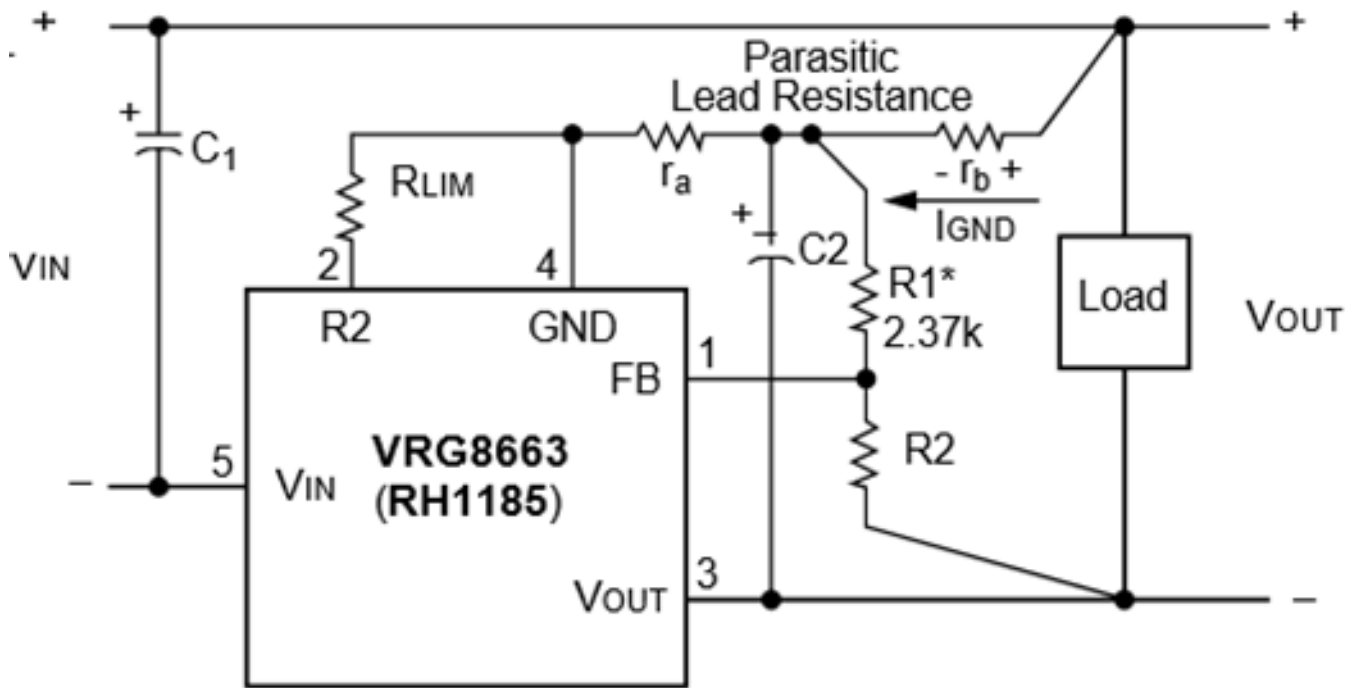

BASIC VRG8663 ADJUSTABLE REGULATOR APPLICATION R1 & R2 LOCATION & PROPER CONNECTION OF POSITIVE SENSE LEAD

*R1 should be connected directly to ground lead, not to the load, so that $r_a=0$. This limits the output voltage error to $(I_{GND})(r_b)$. Errors created by r_a are multiplied by $(1 + R_2/R_1)$. Note that V_{OUT} increases with increasing ground pin current. R_2 should be connected directly to load for remote sensing. $C_1 = C_2 > 2\mu\text{F}$ Tantalum.

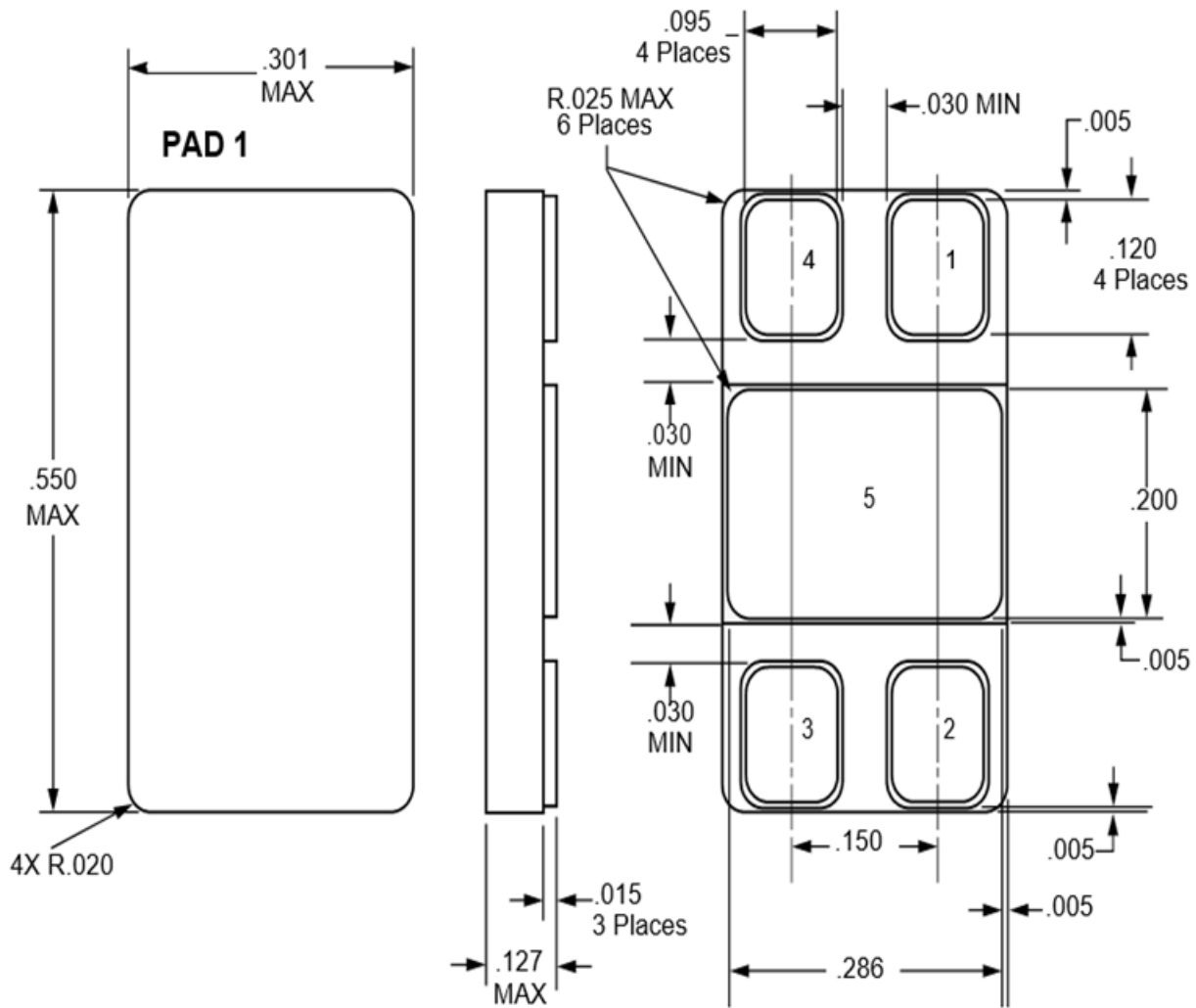

PACKAGE OUTLINE — SURFACE MOUNT

Notes:

Package & Lid are electrically isolated from signal pads.

Ordering Information

MODEL	DLA SMD #	SCREENING	PACKAGE
VRG8663 - 7	-	Commercial Flow, +25°C testing only	SMD Power Pkg
VRG8663 - S	-	Military Temperature, -55°C to +125°C Screened in accordance with the individual Test Methods of MIL-STD-883 for Space Applications	
VRG8663- 201-1S	5962-0920702KYC	In accordance with DLA SMD	
VRG8663- 201-2S	5962-0920702KYA		
VRG8663- 901-1S	5962R0920702KYC		
VRG8663- 901-1S	5962R0920702KYC	In accordance with DLA Certified RHA Program Plan to RHA Level "R", 100 krad(Si)	

Revision History

Date	Revision #	Author	Change Description	Page #
12/11/20	K	CL	REVISED PER ECN 23408	1
11/15/21	L	CL	REVISED PER ECN 23925	1
11/18/21	M	CL	REVISED PER ECN 23939	1
01/23/24	1.0.14	RS	REVISED PER ECN 25161	1

Datasheet Definitions

	Definition
Advanced Datasheet	Frontgrade reserves the right to make changes to any products and services described herein at any time without notice. The product is still in the development stage and the datasheet is subject to change . Specifications can be TBD and the part package and pinout are not final .
Preliminary Datasheet	Frontgrade reserves the right to make changes to any products and services described herein at any time without notice. The product is in the characterization stage and prototypes are available.
Datasheet	Product is in production and any changes to the product and services described herein will follow a formal customer notification process for form, fit or function changes.

Frontgrade Technologies Proprietary Information Frontgrade Technologies (Frontgrade or Company) reserves the right to make changes to any products and services described herein at any time without notice. Consult a Frontgrade sales representative to verify that the information contained herein is current before using the product described herein. Frontgrade does not assume any responsibility or liability arising out of the application or use of any product or service described herein, except as expressly agreed to in writing by the Company; nor does the purchase, lease, or use of a product or service convey a license to any patents rights, copyrights, trademark rights, or any other intellectual property rights of the Company or any third party.