



# FRONTGRADE

## DATASHEET

**59005333**

SCD59005333

Three Output NiPOL DC-DC Converter Module 5V  
in, 0.8 to 3.3V out at up to 6A

2/11/2025

Version #: 1.0.4

## Features

- Three independent NiPOL converters in one convenient package
- Designed for aerospace and high reliability space applications
- Radiation performance
  - Total dose: 50krads (Si), Dose rate = 0.01 rads (Si) / s
  - SEL/SEB/SEGR: Immune up to 43 MeV-cm<sup>2</sup>/mg
- $V_{IN}$  range 4.5V<sub>DC</sub> – 5.5V<sub>DC</sub> for each converter
- $V_{OUT}$  range 0.8V<sub>DC</sub> – 3.3V<sub>DC</sub> for each converter
- Output voltage set by external programming resistor independently for each converter
- Output current up to 6A for each converter
- High Density
- Small volume, 2.36L x 1.79W x 0.600H inch max including pins
- Low weight: 50g, typical
- Gull winged power package enables surface mount installation to provide a low impedance interconnect to system board
- Overcurrent/short circuit protection for each converter
- Configurable Soft-Start for each converter
- Enable/disable control for each converter
- Power Good output from each converter
- 1MHz switching frequency
- -55°C to +125°C operation (T<sub>i</sub>)

## Description

The Frontgrade Three Output NiPOL DC-DC Converter module provides three independent non-isolated point-of-load regulators in one convenient package. The converters share a common ground but have independent 5V inputs. Since they are non-isolated, the input ground and output ground are also common, resulting in a three-terminal regulator configuration. Each converter has an individual load voltage sense input, enable input, power good output, and output voltage programming resistor input.

The converter uses buck topology with secondary synchronous rectification. Overcurrent protection is cycle by cycle. When the individual current limit is exceeded for any converter, it enters a “hiccup” mode until the overcurrent condition is removed.

### Typical Application

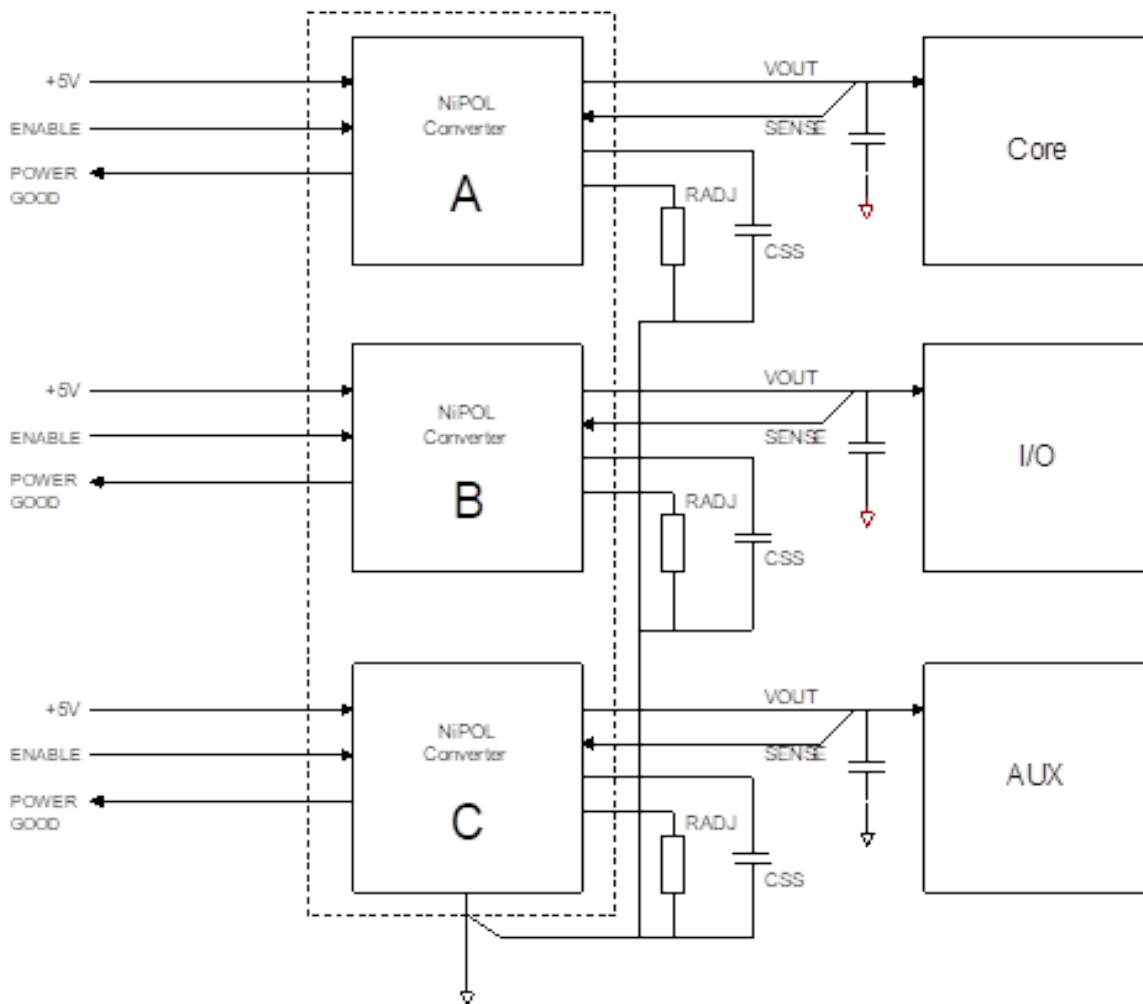

Figure 1 – NiPOL Block Diagram

## Specifications

### ABSOLUTE MAXIMUM RATINGS

PARAMETER	RANGE	UNITS	NOTES
+VIN to GND	-0.3 to 6.5	V <sub>DC</sub>	
EN to GND	-0.3 to +VIN	V <sub>DC</sub>	
SENSE to +VOUT	0 to 0.1	V <sub>DC</sub>	
ADJ to GND	-0.3 to +VIN	V <sub>DC</sub>	
SS to GND	-0.3 to 2.5	V <sub>DC</sub>	
PGOOD to GND	-0.3 to 6.5	V <sub>DC</sub>	
Operating Temperature (T <sub>J</sub> )	-55 to +125	°C	+85 °C maximum recommended pin temperature
Storage Temperature	-55 to +125	°C	

**NOTE:** Stresses above those listed under "Absolute Maximum Ratings" may cause permanent damage to the device.

## Electrical Characteristics

Specifications apply over all line and load conditions over the temperature range of -40°C < T<sub>pin</sub> < +85°C unless otherwise noted.

### PARAMETERS – FOR EACH OF THE THREE CONVERTERS UNLESS NOTED

PARAMETER	SYM	CONDITIONS	MIN	TYP	MAX	UNIT
Input Voltage range	V <sub>IN</sub>		4.5	--	5.5	V
Input	dV <sub>IN</sub> / dt		--	--	1	V/us
Input quiescent current	I <sub>Q</sub>	+VIN=5.5V, No Load, Not Enabled	--	9	13	mA
Input current, No Load	I <sub>IN</sub>	+VIN=5.5V, No Load, Enabled	--	60	85	mA
Output Voltage Range		+VIN=4.5V minimum Set by programming resistor on ADJ pin	0.80	--	3.6	V
Output Current			--	--	6	A
Overcurrent Trip Level			7.8	10.2	15	A
Output voltage rise time (SOFT START – As supplied. May be extended with external capacitors)	Tr	10% to 90% Vout	--	2	--	ms
Enable (EN) Input Voltage		Rising/falling threshold	0.56	0.6	0.64	V
Enable (EN) Sink Current		EN = 0.3V	6.4	11	16.6	mA
Input Capacitance	C <sub>IN</sub>		--	110	--	uF
External Output Capacitance	C <sub>out</sub>	Low ESR required for stability/transient response	150	800	--	uF
Output Voltage Tolerance		Over full temperature range. Add tolerance of ADJ resistor.	--	--	1.25	%
Line Regulation			--	0.01	--	%
Load Regulation			--	0.3	--	%
Output Ripple		Vout = 1V	--	7	--	mv(p-p)

### Typical Efficiency

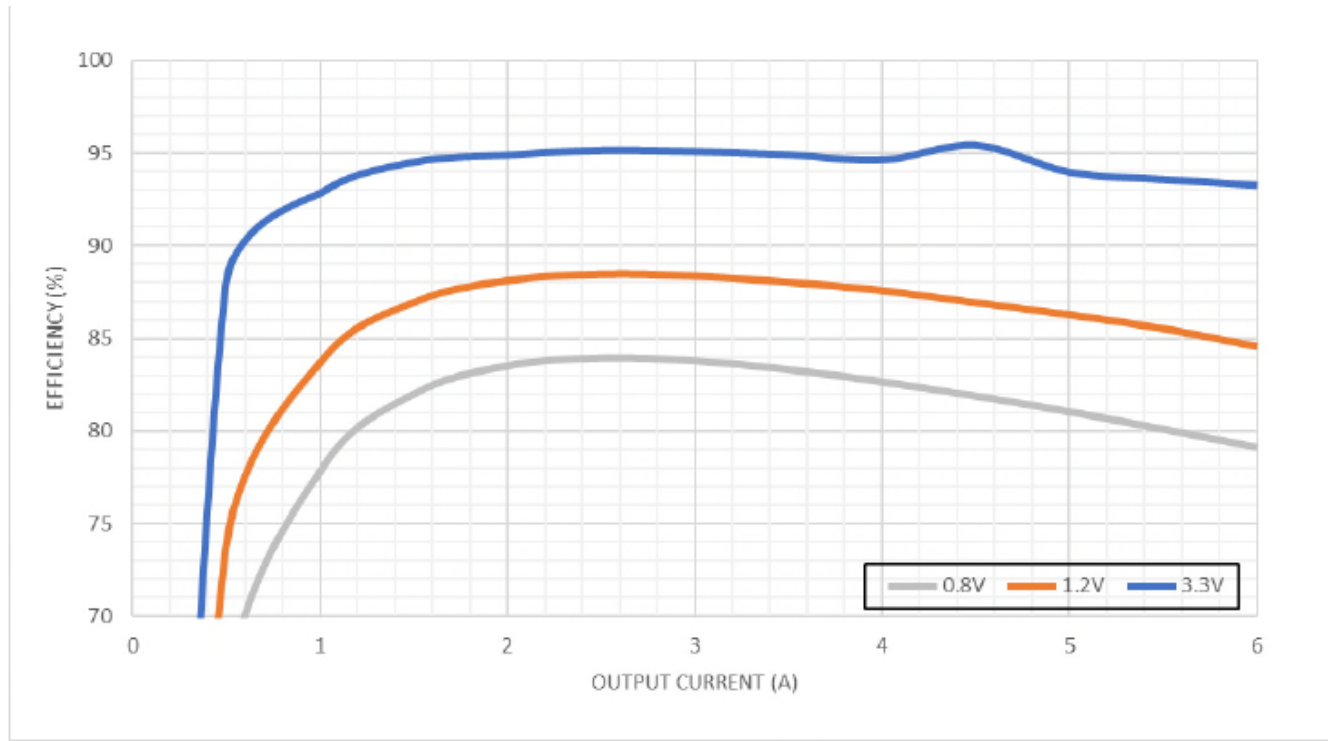
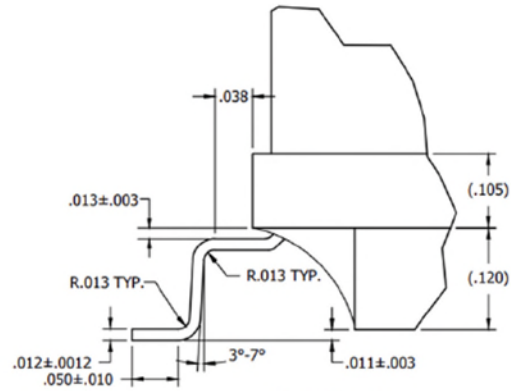
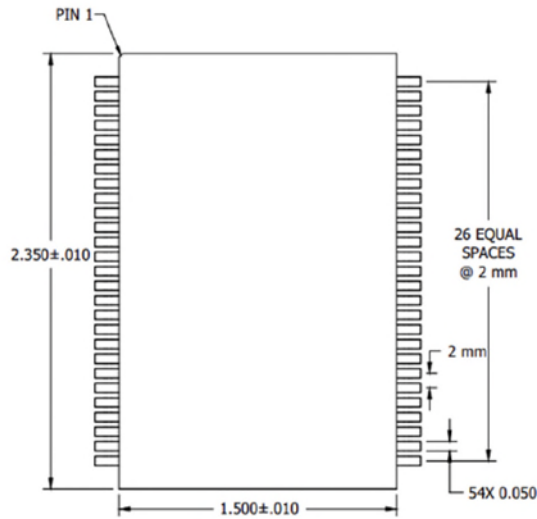

Figure 2 – Typical Efficiency for various output voltages 25°





DETAIL A

DIMENSIONS ARE IN INCHES UNLESS OTHERWISE SPECIFIED

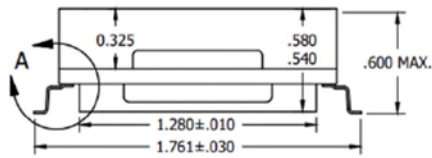

NOTE: Lead Finish Electrolytic Au Over Electrolytic Ni

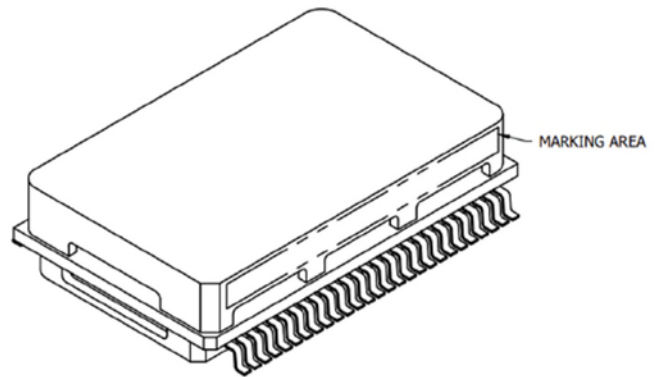

Figure 3 – Module Outline Dimensions

### Mechanical Characteristics

PARAMETER	SYM	CONDITIONS	MIN	TYP	MAX	UNIT
Length	L	-	--	--	2.360	in
Width	W	-	--	--	1.791	in
Height	H	-	--	--	0.600	in
Weight	Wt	-	--	50	55	g
Thermal Impedance	R <sub>θJB</sub>	Junction to Board	--	4	--	°C / W
Soldering tip dwell time per single pin	-	Tip temperature 600°F Assembly pre-heated to 125°F	--	--	6	Sec

NOTE: MAXIMUM REFLOW TEMPERATURE IS 205C

### PINOUT

PIN NO.	SIGNAL	PIN NO.	SIGNAL
1	SENSE_C	54	ADJ_C
2	+VOUT_C	53	EN_C
3	+VOUT_C	52	SS_C
4	+VOUT_C	51	PGOOD_C
5	+VOUT_C	50	GND
6	GND	49	GND
7	GND	48	GND
8	GND	47	+VIN_C
9	GND	46	+VIN_C
10	SENSE_B	45	ADJ_B
11	+VOUT_B	44	EN_B
12	+VOUT_B	43	SS_B
13	+VOUT_B	42	PGOOD_B
14	+VOUT_B	41	GND
15	GND	40	GND
16	GND	39	GND
17	GND	38	+VIN_B
18	GND	37	+VIN_B
19	SENSE_A	36	ADJ_A
20	+VOUT_A	35	EN_A
21	+VOUT_A	34	SS_A
22	+VOUT_A	33	PGOOD_A
23	+VOUT_A	32	GND
24	GND	31	GND
25	GND	30	GND
26	GND	29	+VIN_A
27	GND	28	+VIN_A

## PIN / CONTROL FUNCTIONS

### ADJ – Output Voltage Adjust

Connect a programming resistor between this pin and GND to set the output voltage. With no resistor connected, the output defaults to 0.6 volts out. A 0.01% tolerance, 25ppm resistor is recommended to maintain the output voltage accuracy. The ADJ resistors should be located close to the converter module pins in order to exclude ground voltage offsets. Calculate the external ADJ programming resistor as follows:

First, calculate the total programming resistor using  $R_{tot} = 1/[(V_{out}/.6)-1]$ , where  $V_{out}$  is in volts and  $R_{tot}$  in k-ohms.

Then since there is an internal 10k programming resistor in parallel with the external resistor, calculate the external resistor value using  $R_{adj} = (10 \times R_{tot}) / (10 - R_{tot})$ , where  $R_{adj}$  is in k-ohms.

### EN - Enable

This is a comparator type input with a rising threshold of 0.6V and hysteresis. Driving this pin above 0.6V enables the converter.

### SENSE

Connect this pin as close to the load as possible to reduce the sensitivity of the power converter regulation to the distribution resistance. The SENSE pin should be routed over a ground plane or guarded by ground traces to reduce spurious pickup. If the SENSE pin is not connected, the converter will regulate at its output pin.

### SS – Soft Start

This pin allows for rise time longer than the default 2 ms by adding an external capacitor. The 10% to 90% rise time can be calculated by the following function in which  $C_{ss}$  is the external capacitance:

$$C_{ss} = (T_{rise} / 20) - 0.1$$

where  $T_{rise}$  is in ms,  $C_{ss}$  in uF

### PGOOD – Power Good Output

This pin is an open-drain logic output that is pulled to GND when the output voltage is outside a  $\pm 11\%$  typical regulation window. This pin can be pulled up to any voltage from 0V to 5.5V, independent of the supply voltage. A nominal 1k $\Omega$  to 10k $\Omega$  pull-up resistor is recommended.

## LAYOUT RECOMMENDATIONS

The following layout guidance is provided in order of priority:

1. Power output should be connected to one or more internal planes or partial planes. Extra vias should be provided to reduce ohmic losses to the extent feasible.
2. Output capacitance should be located to minimize the impedance between it and the devices being powered.



### Ordering Information

Model	DLA SMD #	Screening	Package
5900533 -7	—	Commercial Flow, +25°C testing only	54-lead PCB Module
5900533 -S		High Reliability Space Grade Operating Temperature Range -55°C to 125°C Screened in accordance with MIL PRF 38534, Class L	



### Revision History

Date	Revision #	Author	Change Description	Page #
02/11/2025	1.0.4		Revised per ECN 25706, Import into Frontgrade format, update various technical information, add ordering information.	

### Datasheet Definitions

	Definition
Advanced Datasheet	Frontgrade reserves the right to make changes to any products and services described herein at any time without notice. The product is still in the development stage and the <b>datasheet is subject to change</b> . Specifications can be <b>TBD</b> and the part package and pinout are <b>not final</b> .
Preliminary Datasheet	Frontgrade reserves the right to make changes to any products and services described herein at any time without notice. The product is in the characterization stage and prototypes are available.
Datasheet	Product is in production and any changes to the product and services described herein will follow a formal customer notification process for form, fit or function changes.

**Frontgrade Technologies Proprietary Information** Frontgrade Technologies (Frontgrade or Company) reserves the right to make changes to any products and services described herein at any time without notice. Consult a Frontgrade sales representative to verify that the information contained herein is current before using the product described herein. Frontgrade does not assume any responsibility or liability arising out of the application or use of any product or service described herein, except as expressly agreed to in writing by the Company; nor does the purchase, lease, or use of a product or service convey a license to any patents, rights, copyrights, trademark rights, or any other intellectual property rights of the Company or any third party.