

Temperature Fault Detection and Recovery with a Quad Voltage Supervisor

Overview

The Quad Voltage Supervisors are useful in Fault Detection, Isolation and Recovery (FDIR) schemes where they monitor for system fault conditions then isolate and reset circuitry to recover from these faults. One such application uses the UT04VS33P Quad Voltage Supervisor and an RHD5962 Buffered Thermometer to monitor for temperature faults outside of a user-defined range. The RHD5962 thermometer monitors the temperature source and generates a voltage output that tracks linearly with temperature. The Quad Supervisor uses its voltage comparator channels to define a min/max tolerance range for the buffered thermometer and generates error and reset flags whenever the monitored temperature moves outside this defined range.

Product Features and Block Diagrams

The RHD5962 Buffered Thermometer in Figure 1 behaves as a temperature-controlled voltage reference that linearly converts the measured temperature to a voltage, VTHERM. A plot of voltages presented on the VTHERM pin over the rated operating temperature range of -55°C to $+125^{\circ}\text{C}$ is shown in Figure 2.

Monitoring the VTHERM voltage for out- of-range events, the UT04VS33P Quad Voltage Supervisor generates error flags and resets to isolate and recover from temperature faults.

The Quad Supervisor shown in Figure 1 contains four independent voltage comparators that measure the VINx inputs against an internal reference voltage, VRFTH. The threshold select inputs, TH0 and TH1, define internal resistor dividers to adjust the VINx voltage for comparison to VRFTH.

Table 1 Quad Supervisor Input Voltage Threshold Selection

TH1	TH0	VIN1	VIN2	VIN3	VIN4
0	0	3.3	2.5	1.8	1.5
0	1	3.3	1.8	1.5	1.2
1	0	3.3	1.5	1.2	1
1	1	ADJ	ADJ	ADJ	ADJ

Adjustable threshold selection (TH1=TH0=1) requires external resistor dividers to adjust the VINx voltage.

Temperature Fault Detection and Recovery with a Quad Voltage Supervisor

UT04VS33P Voltage Supervisor

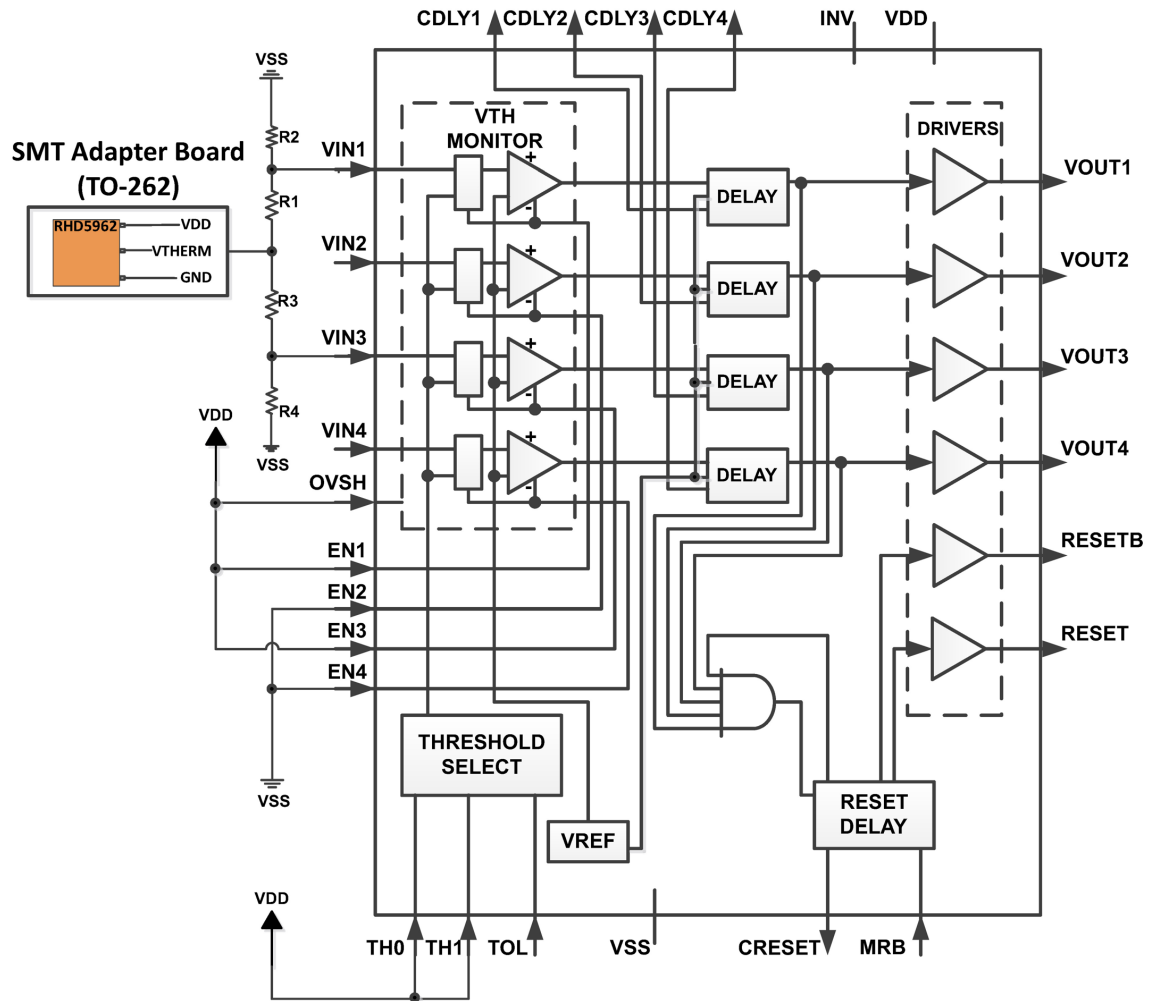

Figure 1 UT04VS33P Voltage Supervisor with RHD5962 Temperature Buffer connected for Temperature Fault Monitoring

Temperature Fault Detection and Recovery with a Quad Voltage Supervisor

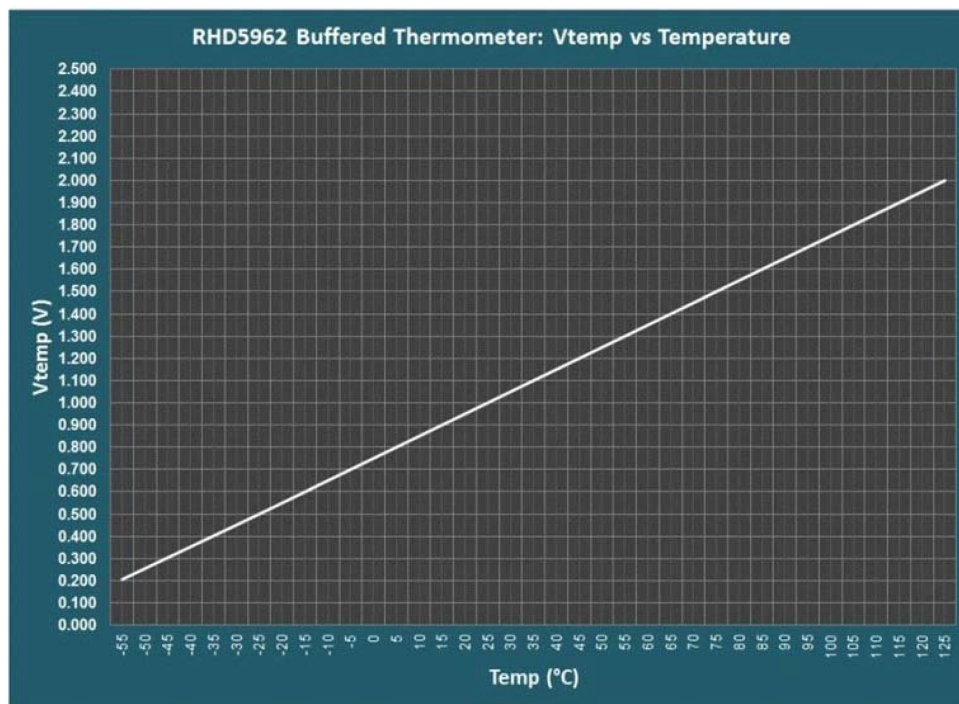

Figure 2 RHD5962 Linear temperature conversion

Temperature Fault Monitor Application

Figure 1 shows a notional schematic of the RHD5962 Buffered Thermometer and the UT04VS33P Quad Channel Voltage Supervisor used in this application. Figure 3 shows the lab set-up with the UT04VS33P Evaluation Board and the RHD5962 Buffered Thermometer mounted to a TO-262 DPAK adapter board.

Temperature Fault Detection and Recovery with a Quad Voltage Supervisor

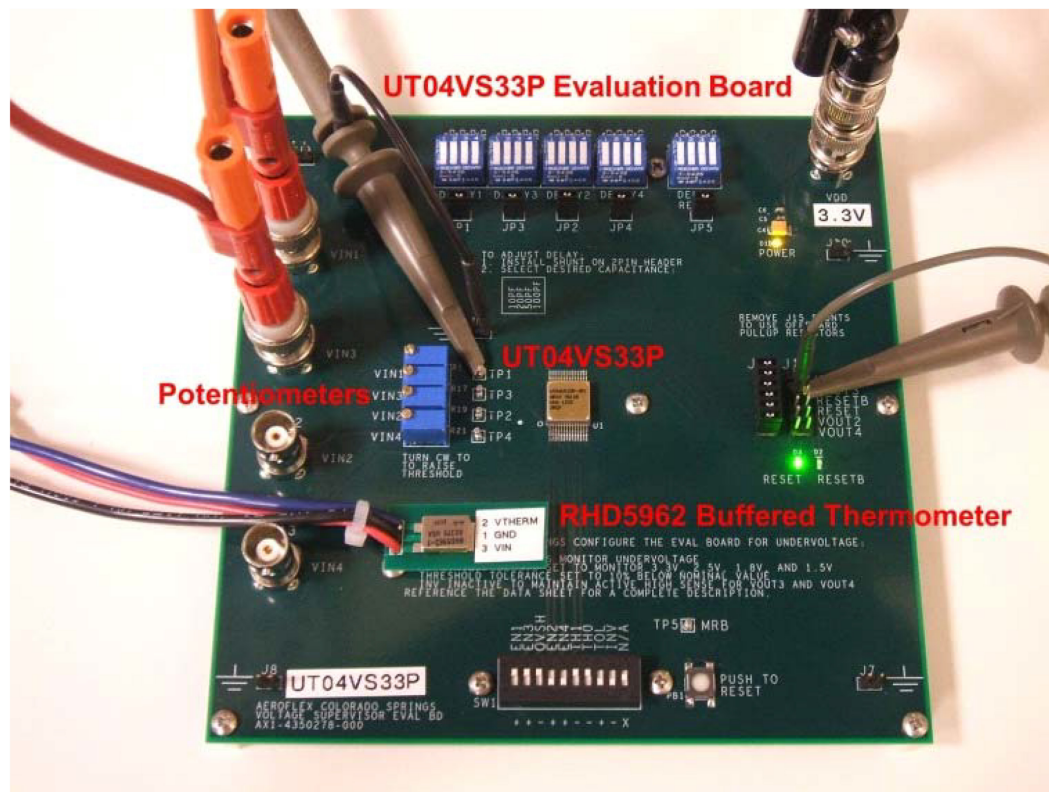

Figure 3 UT04VS33P Voltage Supervisor Evaluation Board with RHD5962 Temperature Buffer mounted on a TO-262 adapter board.

The VTHERM output of the Buffered Thermometer connects through a voltage divider to both the VIN1 and VIN3 comparator inputs on the Quad Supervisor. The over-voltage select input, OVSH, is set HIGH to place the Supervisor in over-voltage/under-voltage (OVSH) mode. In OVSH, the Supervisor checks for under-voltage faults on channels VIN1 and VIN2 and over-voltage faults on VIN3 and VIN4. The combined fault comparison of VIN1 and VIN3 appears at the VOUT1 output. The combined (that is, ANDed, logically) result of VIN2 and VIN4 appears at the VOUT2 output. In OVSH mode, VOUT3 and VOUT4 are unused.

Enables EN1 and EN3 are HIGH to enable these two channels for monitoring while EN2 and EN4 are LOW to remove these comparators from the analysis and eliminate their effect on the system resets, RESET/RESETb. Threshold selects TH0 and TH1 are set HIGH to select adjustable threshold mode. External resistor dividers adjust the VTHERM monitor voltage for comparison to the internal reference, VRFTH. The first resistor divider, R1 and R2, defines the under-voltage threshold minimum as $VIN1=VTHERM*[R2/(R1+R2)]$. The second resistor divider, R3 and R4, defines the over-voltage threshold maximum as $VIN3=VTHERM*[R4/(R3+R4)]$. To define the voltage range in this application, the resistance potentiometers on the evaluation board were set to measured values of $R1=33.1k\Omega$, $R2=72.9k\Omega$, $R3=44.7k\Omega$ and $R4=62.4k\Omega$. Assuming a nominal reference threshold voltage of 600mV for the UT04VS33P, this defines a nominal threshold for under-voltage events on VIN1 of 0.872V (temperature = 15°C). Similarly the nominal threshold for over-voltage events on VIN3 is 1.029V (temperature = 30°C).

In the lab, a Thermonics Precision Temperature Forcing system adjusted the temperature on the RHD5962 Thermometer while an oscilloscope and voltmeter measured the actual fault voltages. Table 2 summarizes the data. Table 4

Temperature Fault Detection and Recovery with a Quad Voltage Supervisor

shows a reset activated by an under-voltage/ cold fault, while Table 5 depicts a reset removal when an over-voltage/hot fault returns to ambient range.

Table 2 Measured Voltage for Fault Reset and Removal

Condition	Reset/ Reseth	Calculated Trigger (V)	Actual Trigger (V)
Ambient to Cold	Active	0.872	0.876
Cold to Ambient	Removed	0.872	0.895
Ambient to Hot	Active	1.029	1.044
Hot to Ambient	Removed	1.029	1.025

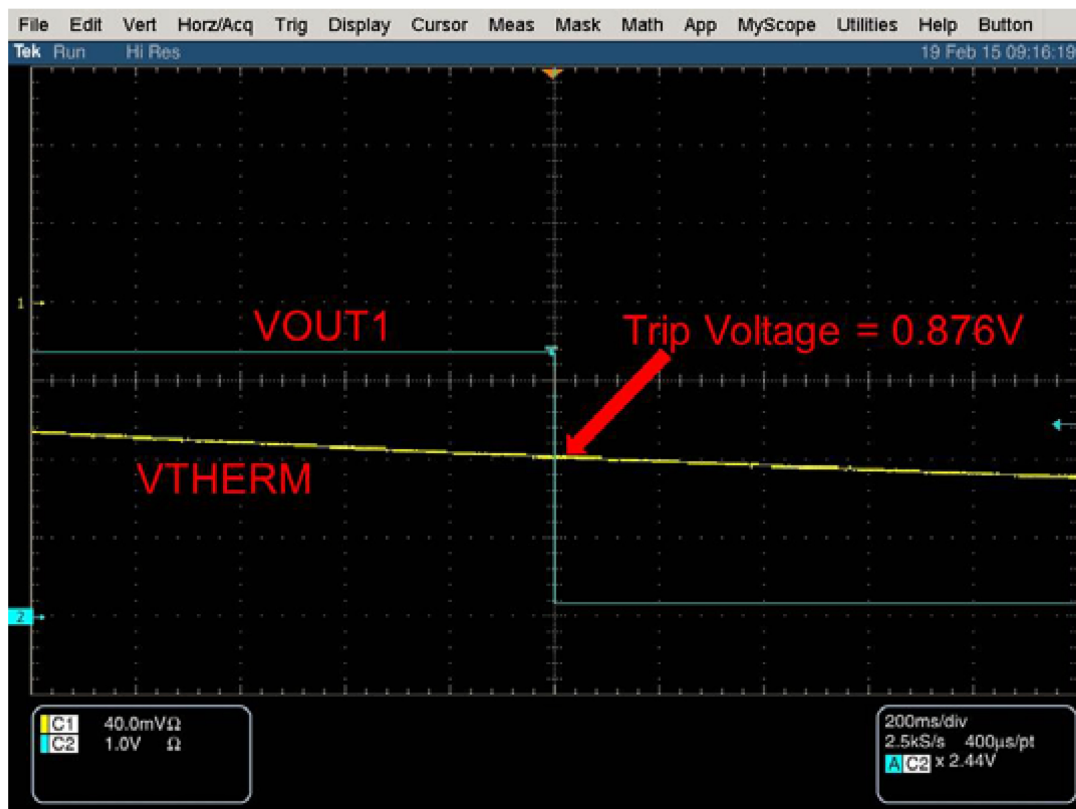

Figure 4 Under-voltage / Cold Reset activated by voltage below threshold

Temperature Fault Detection and Recovery with a Quad Voltage Supervisor

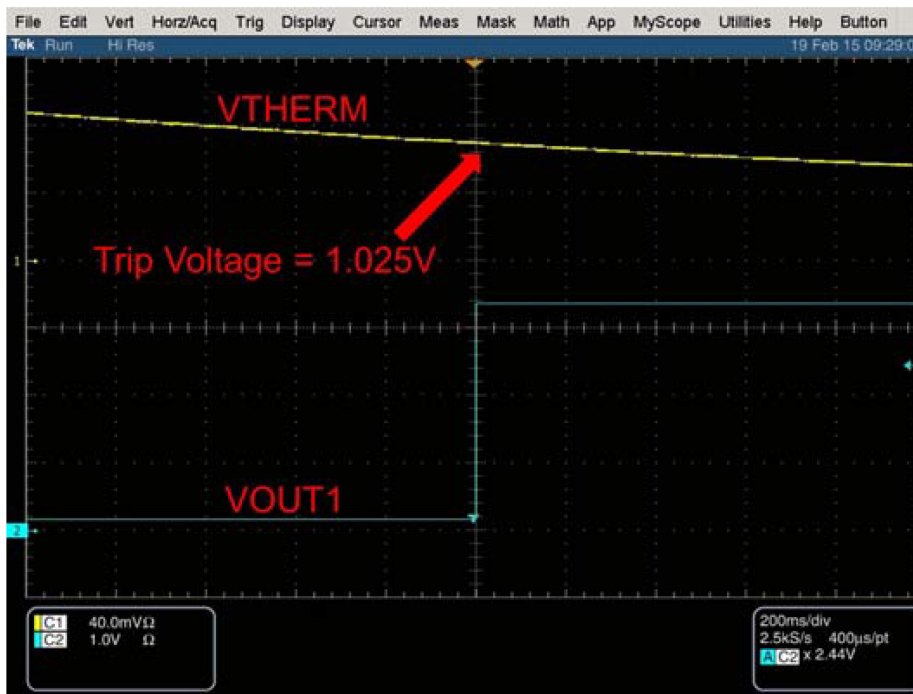

Figure 5 Over-voltage / Hot Reset Removal as voltage returns to ambient

Conclusions

In this application, the UT04VS33P Quad Voltage Supervisor combines with an RHD5962 Buffered Thermometer to monitor a system for temperature faults. The Thermometer converted a temperature range to a voltage for comparison with the Quad Supervisor. The Supervisor generated VOUT and RESET signals for isolation and recovery from the detected fault. The measured fault voltages varied from the calculated values due to tolerances throughout the measurement system, the evaluation board components, and the bandgap voltage and hysteresis of the UT04VS33P device. The monitored temperature range for this application extends only to approximately -15°C. The Thermometer V_THERM voltage at this temperature is 600mV, which is the internal reference voltage, V_{RFTH}, generated for the Supervisors comparators. Inserting a RHD5961 2.0V Precision Voltage Reference for positive voltage comparison against the RHD5961 instead of V_{SS} referencing would extend the cold temperature V_THERM range for this application.

The following United States (U.S.) Department of Commerce statement shall be applicable if these commodities, technology, or software are exported from the U.S.: These commodities, technology, or software were exported from the United States in accordance with the Export Administration Regulations. Diversion contrary to U.S. law is prohibited.