

SpaceWire Explained in Six Pages

Table 1: Cross Reference of Applicable Products

Product Name:	Manufacturer Part Number	SMD #	Device Type	Internal PIC*
SpaceWire Physical Layer Transceiver	UT200SpWPHY01	5962-06232	01, 02	WD37
4-Port SpaceWire Router	UT200SpW4RTR	5962-08244	01, 02	WD41
SpaceWire Protocol Handler IP	UT100SpW02	--	01, 02, 03, 04, 05	--

*PIC = Product Identification Code

1.0 Overview

SpaceWire is a self-managing point-to-point serial interface that provides high speed, low power operation while offering a flexible user protocol. The SpaceWire Standard ECSS-EST-50-12C calls for a Low Voltage Differential Signaling (LVDS) physical layer as defined in ANSI/TIA/EIA-644, Electrical Characteristics of Low Voltage Differential Signaling Interface Circuits. This application note discusses the basic concepts of how SpaceWire works.

The SpaceWire (SpW) protocol breaks down into six layers. The physical layer: defines connectors, cables, cable assemblies, etc. Signal layer: defines encoding, voltage levels, noise margins, and signaling rates. Character layer: defines the data and control characters used to manage data across a link. Exchange layer: defines the protocol for link initialization, flow control, link error detection and link error recovery. Packet layer: manages data packetization and transmission over a SpW link. Network layer: defines the structure of a SpW network and source to destination node data transfers. The Network layer also defines link errors and network level error management. Figure 1 shows the layers of the SpW protocol.

During normal operation, a SpaceWire host node manages data by sending tokens to a destination node on the other end of the link. Each token indicates to the destination node that the host has 8 bytes of available buffer space. The destination node's credit counter records each token that is receives. Three tokens indicate 24 bytes of available buffer space at the host side, allowing the destination node to send 24 bytes of data to the host.

SpaceWire Explained in Six Pages

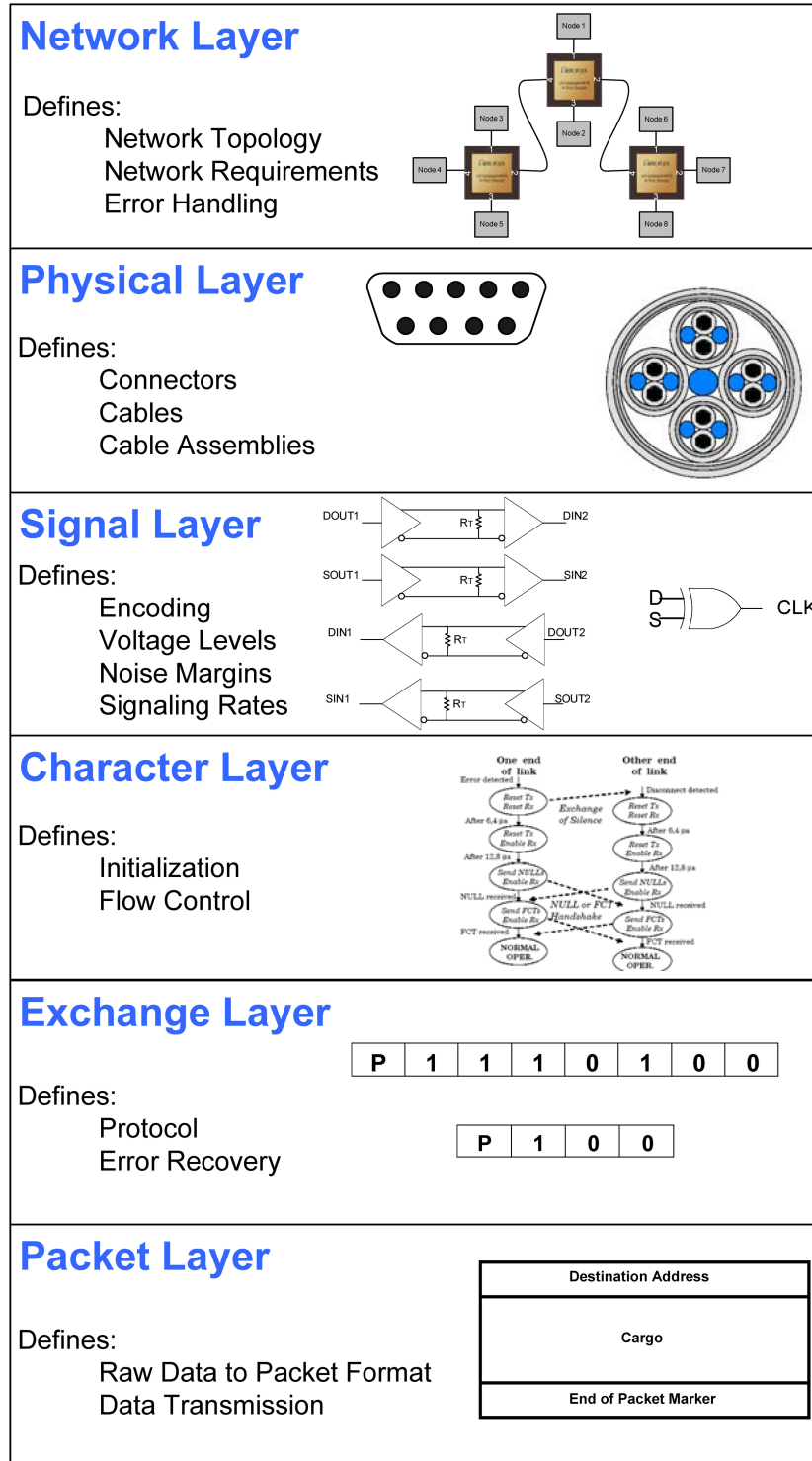

Figure 1. SpaceWire OSI Type Mode

SpaceWire Explained in Six Pages

2.0 LVDS Physical/Signal Layer

Communications such as packet and token passing across a SpW network, execute using Low Voltage Differential Signaling (LVDS). LVDS is useful in applications that require low power, low noise, and high-speed point-to-point communications. The SpaceWire physical layer uses Data-Strobe (DS) Encoded LVDS to communicate serial, full-duplex, bidirectional data. Figure 2 depicts a notional SpaceWire Link using the LVDS physical layer. ANSI/TIA/EIA-644 defines the electrical Input/Output signal levels only; it does not define a protocol. Instead, the protocol is defined in the SpaceWire Standard specification ECSS-S-ST-50-12C, derived from IEEE 1355-1995.

LVDS is a method used to transmit and receive hundreds of megabits per second over differential media using a low voltage signal swing (~350mV) using a driver and a receiver. The driver accepts a standard Complementary Metal Oxide Semiconductor (CMOS) signal and outputs a constant current, 3.5mA, differential signal. The driver output current travels through a 100Ω resistive load located across the receiver inputs. The current flow through the resistor results in a 350mV potential across the differential terminals. The LVDS receiver senses this voltage and outputs a standard CMOS signal. The direction of the driver's constant current will determine the logic state at the receiver.

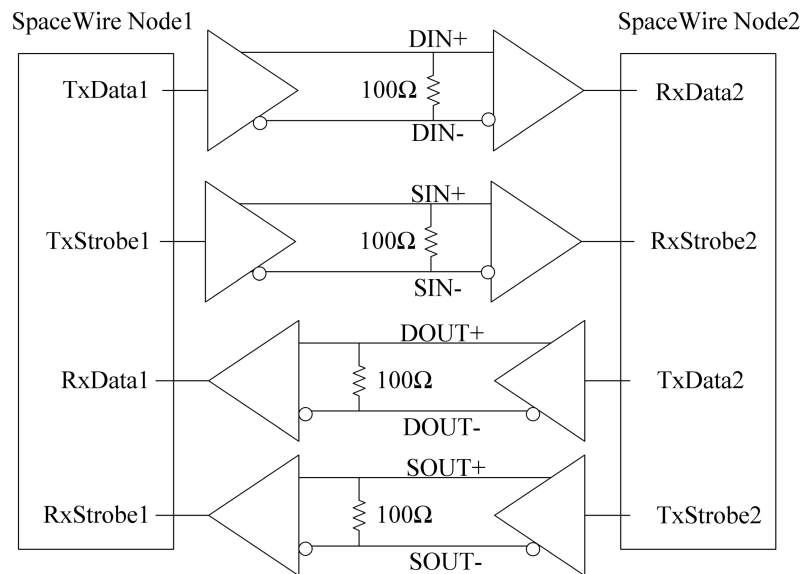
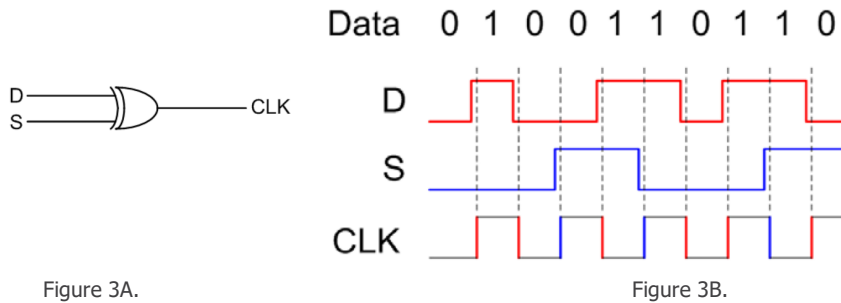

Figure 2. Single point to point SpaceWire Link

SpaceWire uses Data Strobe (DS) encoding to send information over the LVDS links. The data value is transmitted directly and the strobe signal changes state whenever the data remains constant from one data bit interval to the next. XORing the data and strobe signals as shown in Figure 3A and 3B result in a synchronous clock. There is a slight delay between edges of D and S and recovered clock. Data is non return to zero, (NRZ). A data rate of 100Mbps equates to a 50MHz clock.

SpaceWire Explained in Six Pages



3.0 Character Layer

The ECSS-E-ST-50-12C standard defines two types of characters, data and control characters. These characters are further defined as either link characters or normal characters. The Exchange Layer does not pass a link character to the Packet Layer. Meaning that a link character does not get entered into the memory space of a SpaceWire node, this is explained in further detail below in Figure 4. Flow control token (FCT), escape characters (ESC) as well as NULL control code (ESC + FCT) and the Time code characters (ESC + data character) are link characters. A Normal Character ends with an EOP or EEP and passes through a SpW network at a packet layer.

P	1	0	0	FCT: Flow Control Token						
P	1	0	1	EOP: End of Packet marker						
P	1	1	0	EEP: Error End of Packet						
P	1	1	1	ESC: Escape character						
P	0	D0	D1	D2	D3	D4	D5	D6	D7	Data Character

Figure 4. Control and Data Character Definitions.

Data characters contain a parity bit, data-control flag, and an eight-bit data value, transmitted LSB to MSB. The even or odd parity bit is calculated by adding the number of ones that are contained in the previous 8-bits data. Meaning if the number of 1's in bits added together is even, the data character is said to have even parity. There are two Control Characters that are formed using control characters and data characters, these are the NULL and Time Code Characters. NULL characters are used during the initialization sequence and are also sent to keep the LVDS SpW lines active when no data is being sent. Distributing system time is accomplished using Time Codes. The use of time codes is optional.

4.0 Exchange Layer

The exchange layer defines the mechanisms for link initialization, link flow control, link error detection, and link error recovery. The initialization state machine causes a SpW link to continuously attempt initialization as long as the link is active. Detection of disconnect errors occurs after 850ns of no data and strobe transitions. A parity error is detected when the first bit the next character sent. Once an error occurs, the link recovery state machine is automatically evoked.

SpaceWire Explained in Six Pages

Figure 5 shows a simplified state diagram of the initialization and error recovery sequence a SpaceWire node must follow in order to be compliant with the standard, ECSS-E-ST-50-12C. The initialization flow is executed upon initial start up of the link or reset (which occurs at 10Mbps) when an error is detected (Parity Error, Escape Error, etc), or link disconnect occurs.

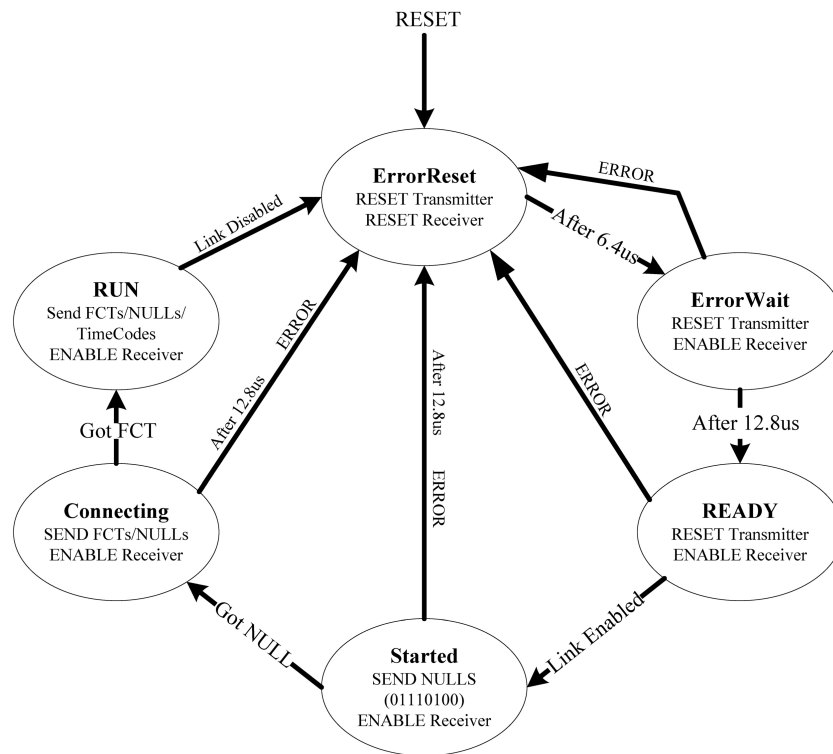

Figure 5. Simplified SpaceWire Initialization State Machine

5.0 Packet and Network Layer

The format of a SpW packet is very flexible. The packet simply needs a destination address 1 to n bytes of data characters representing the destination path of the packet. Cargo consisting of the transmission data, there is no limit to the size or format of the Cargo. An End of Packet Marker (EOP) signals the end of cargo transmission. SpaceWire supports data transfer from 2 to 400Mbps. Figure 6 shows the SpW packet format.



Figure 6. SpW Packet Format

SpaceWire Explained in Six Pages

Packets are passed through a Network composed of Nodes, Links, and Routers. SpaceWire nodes can be routers, sensors, memory units, processors, and telemetry sub-systems. Nodes represent the source and destination of SpW packets and provide the interface to the application systems. The SpaceWire Standard has an extensive list of options for networking with SpaceWire some of these are Wormhole Routing, Path Addressing, Logical Addressing, and Group Adaptive Routing.

Distributed and Centralized network topologies offer the designer much flexibility. Distributed networks provide lower harness mass, good throughput performance, require look-up tables to be configured, and offer increased reliability through redundant paths. Centralized networks provide higher harness mass, high throughput performance, simple configuration, and heavy reliance on the central router decreasing fault tolerance. A redundant network design ensures that the system remains functional if one or more of the systems components fail. Many other topologies are possible. Each topology has tradeoffs that must be considered. See Figures 7A and 7B for notional examples of centralized and distributed networks.

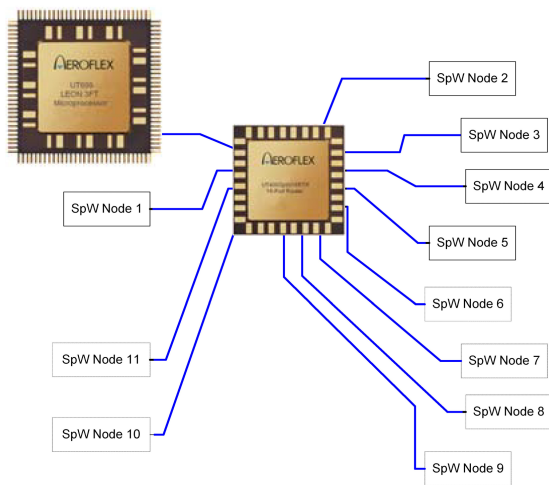

Figure 7A.

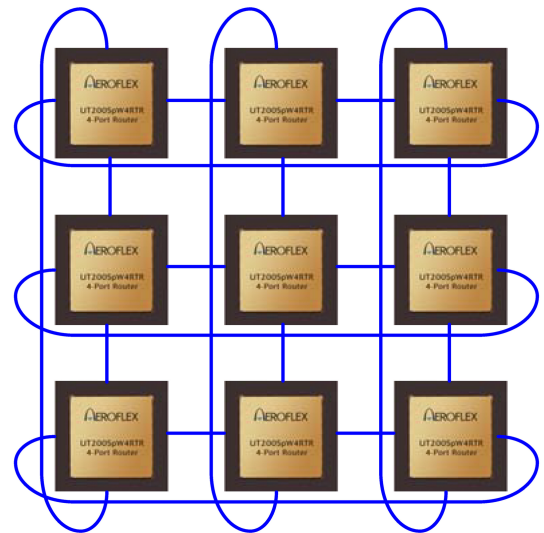

Figure 7B.

6.0 Summary

SpaceWire is a point-to-point bit shipping protocol where the user defines the format of data sent and received. Using LVDS as the physical layer reduces the power in the system while the differential aspect improves the noise immunity. The flexibility of the protocol, packet size, and network configuration possibilities make SpaceWire an ideal solution for communications in high reliability systems.

SpaceWire Explained in Six Pages

7.0 References

- 1) Telecommunications industry Association, "Electrical Characteristics of Low Voltage Differential Signaling (LVDS) Interface Circuits ANSI/TIA/EIA-644", January 30, 2001.
- 2) IEEE P1355, "Standard for Heterogeneous InterConnect (HIC) IEEE 1355-1995", Conference Title, Location, June 12, 1996.
- 3) ESA Publications Division, "SpaceWire Standard Document ECSS-E-ST-50-12C", The Netherlands, July 31, 2008.

The following United States (U.S.) Department of Commerce statement shall be applicable if these commodities, technology, or software are exported from the U.S.: These commodities, technology, or software were exported from the United States in accordance with the Export Administration Regulations. Diversion contrary to U.S. law is prohibited.